



REAL TIME CROSS CORRELATION



RoHS

HA7402C

PHASE NOISE ANALYZER

10 MHz to 6GHz
Optional to 20GHz

Cross Correlation
Fast Data Acquisition

DATA SHEET April 2016

PRELIMINARY



PRODUCT SUMMARY

The HA7402C tunable phase noise analyzer responds to industry demands for a no frills phase noise measurement system that is highly reliable and intuitive while offering measurement speeds that eliminate bottlenecks on manufacturing test lines. The HA7402C is also an incredibly cost effective solution for R&D, offering measurement floors below -190dBc/Hz.

The core engine combines the best of traditional analog phase noise measurement front-ends (being virtually spur free) with the latest technology in cross correlation analysis. The digital analysis system leverages a proprietary DSP with a powerful cross correlation engine.

External LOs are used with this unique architecture to achieve the lowest phase noise floors as well as blazing fast measurement speeds. Two separate LOs are necessary, as the engine requires non-coherent signals in order to cross correlate. The integrated frequency counters and power meters make the use of external LOs straight forward with a fully automated calibration routine.

Phase noise measurements do not benefit from modular analyzer architectures. Holzworth's fully shielded, fan-less 1U chassis completely eliminates ground loops and troublesome microphonics for uncompromising performance when compared to traditional "rack and stack" style systems.

ANSI Z540 CALIBRATED ACCURACY
SIMULTANEOUS AM/PM MEASUREMENTS
ULTRA LOW PHASE NOISE FLOORS
HIGH SPEED DATA ACQUISITION
AUTOMATED - ABSOLUTE & RESIDUAL
3 YEAR MANUFACTURER WARRANTY



PRODUCT SUMMARY - BLOCK DIAGRAM

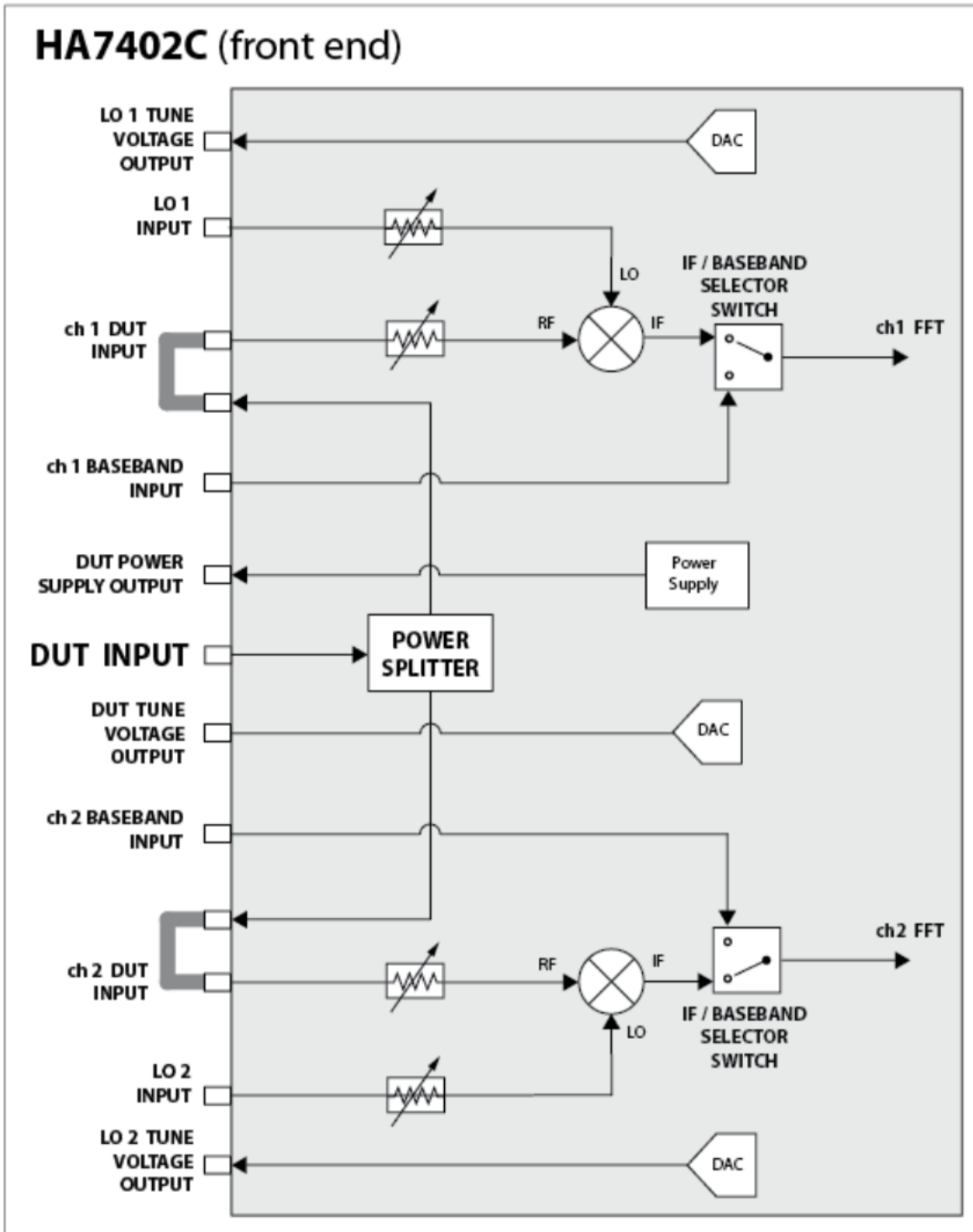

Figure 1: HA7402C Front End Block Diagram

SPECIFICATIONS - ELECTRICAL

The HA7402C is designed for high speed and precise phase noise measurements. The specifications outlined here capture the baseline performance and features that are currently available from the HA7402C phase noise analyzer. The highly reliable hardware is capable of additional functionality for custom requirements. Inquire with Holzworth Instrumentation or your local sales representative.

RF INPUT (DUT/LO)

DESCRIPTION	SPECIFICATION
RF Input Connector	SMA (female), 50 ohm
RF Input Frequency Range (standard)	10 MHz to 6 GHz
RF Frequency Extension (>20GHz)	Option OPT-DUT20 enables >20GHz frequency measurements
RF Input Measurement Level	0 dBm to +20 dBm
Input Damage Level	+22 dBm
Input VSWR	< 2.0:1

PHASE NOISE MEASUREMENTS

DESCRIPTION	SPECIFICATION
RF Input Frequency Range	10 MHz to 6 GHz
RF Frequency Extension (>20GHz)	Option OPT-DUT20 enables >20GHz frequency measurements
RF Tracking Range	±10ppm (typical), ± 5ppm (specified)
Offset Frequency Range	1 Hz – 40 MHz (Settable to 0.1Hz Offset)
Phase Noise Uncertainty 1 Hz to 1 kHz offset 1 kHz to 1 MHz offset 1 MHz to 40 MHz offset	± 4 dB (to be updated with improved uncertainty resulting from z540.1 calibration statistics) ± 2 dB (to be updated with improved uncertainty resulting from z540.1 calibration statistics) ± 2 dB (to be updated with improved uncertainty resulting from z540.1 calibration statistics)
x Correlation	See pages 5-7
Measurement (Sample) Time	See Table 1

TABLE 1: PHASE NOISE MEASUREMENT SPEED (SAMPLE TIME)

Frequency Offset Range	Sample Time
10kHz - 40MHz	10x period of minimum offset frequency.
1kHz - 40MHz	
100Hz - 40MHz	
10Hz - 40MHz	
1Hz - 40MHz	

TABLE 2: x CORRELATIONS vs. PHASE NOISE IMPROVEMENT

 Improvement factor: $\text{dB} = 5\log N$ (N = No. of correlations)

Number of Correlations	1	10	100	1,000	10,000
dB Improvement	0dB	5dB	10dB	15dB	20dB

INTERNAL TIME BASE (10MHz Reference)

DESCRIPTION	SPECIFICATION
Frequency Uncertainty / Stability	$< \pm 1\text{Hz}$ at 10MHz (± 100 ppb) At time of shipment. Factory calibrated at +21C.
Frequency Temperature Effects	$< 10\text{ppb}$
Frequency Aging Rate	$< 100\text{ppb/yr}$
10MHz External Lock Range	$\pm 20\text{Hz}$ (typical), $\pm 10\text{Hz}$ (specified). 10MHz is for frequency counters only.

LO MODES

MODE	DESCRIPTION
External LO Mode	User supplied LO sources. Auto calibration of LO sources and auto phase lock. Pages 10-11.

REAL TIME CROSS CORRELATION PROCESSING ADVANTAGE

The HA7402C processes data across the entire measurement offset bandwidth in real time. Data at higher frequency offsets undergoes continuous processing while the system is accumulating data closer to the carrier. This results in improved phase noise floor performance at higher offset frequencies. The plot below demonstrates the phase noise improvement that can be expected based on the minimum frequency offset chosen.

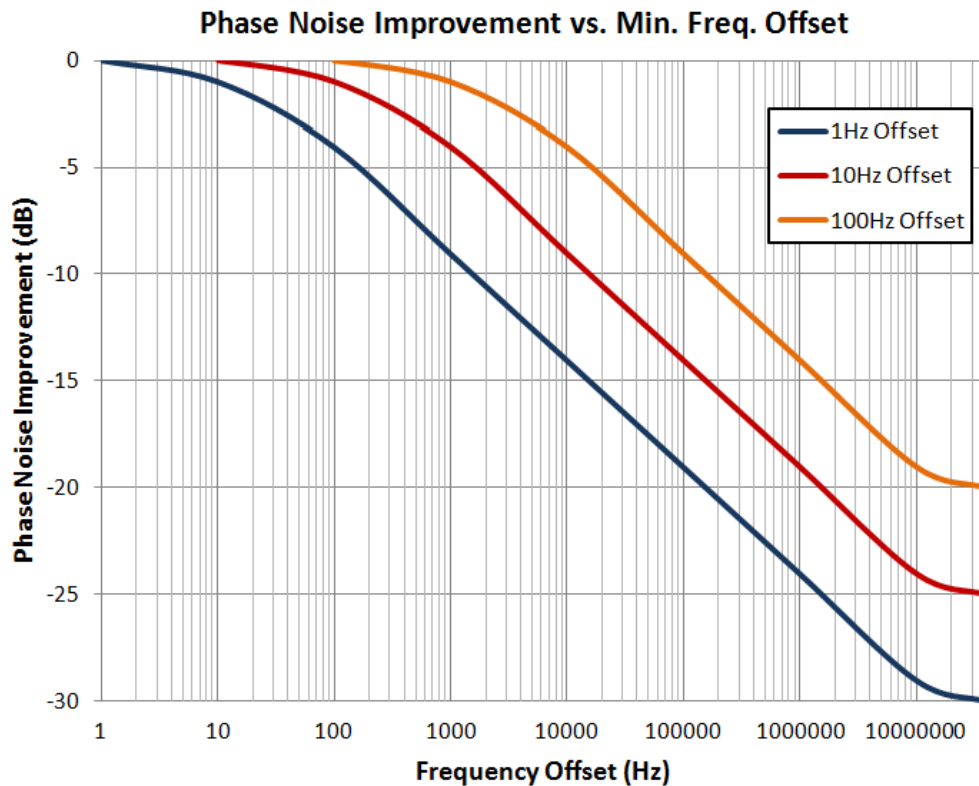

CONFIGURATION

FRONT PANEL

The HA7402C allows for a high level of measurement flexibility to accommodate different test scenarios by allowing the user access to various system inputs points. However, only the DUT Input port is necessary for making straight forward absolute phase noise measurements of a frequency source.

DESCRIPTION	SPECIFICATION
Front Panel Connector(s) Type	SMA (3.5mm), 50ohm
DUT Input Frequency Range (standard) Power Level Range Input Damage Level	10MHz to 6GHz 0dBm to +20dBm > +22dBm
DUT Tune Voltage Voltage Tune Range Max Current	For Vcc control of some DUTs. Limited current for operation as a power supply. -10V to +10V 5mA
DUT Power Supply Voltage Supply Range Maximum Current	Integrated power supply. 0V to +12V 300mA
LO1/LO2 Input(s) Frequency Range (standard) Power Level Range Input Damage Level	Connect to LO1/LO2 Output(s) for standard operation. 10MHz to 6GHz 0dBm to +20dBm > +22dBm
LO1/LO2 Tune Voltage Voltage Tune Range Max Current Tuning Sensitivity	For independent Vcc control of external LO sources during External LO Mode of operation. -10V to +10V 5mA TBD
ch1/ch2 Splitter Bypass Input(s) Frequency Range (standard) Power Level Range Input Damage Level	Allows user to bypass DUT power splitter for direct access to the FFT engine. Connect to ch1/ch2 Splitter Bypass Output(s) for standard operation. 10MHz to 6GHz 0dBm to +14dBm > +16dBm
ch1/ch2 Splitter Bypass Output(s)	Connect to ch1/ch2 Splitter Bypass Input(s) for standard operation.
ch1/ch2 Baseband Input(s) Frequency Range Power Level Range Input Damage Level	DC to 40MHz ± 1Vdc ± 2Vdc, or 50mA (whichever is greater)

CONFIGURATION (continued)

REAR PANEL

DESCRIPTION	SPECIFICATION
Reference Output Port Connector Type Output Frequency Output Level Output Waveform	SMA, 50ohm 10MHz \pm 10Hz +5dBm \pm 2dBm Sinusoid
Reference Input Port Connector Type Input Frequency Input Level	ONLY FOR FREQUENCY COUNTERS - DOES NOT AFFECT MEASUREMENT SENSITIVITY SMA, 50ohm 10MHz \pm 10Hz 0dBm to +10dBm (Sinusoid or Square)
AC Power Input Connector Type AC Input Rating	IEC 320-C13 100-240V _{AC} , 47-63Hz. Specify country at time of order.
Data I/O Interface Connectivity Storage	USB B-Type (virtual comm. port), Ethernet, RS-232, GPIB SD Card Reader

CONFIGURATION

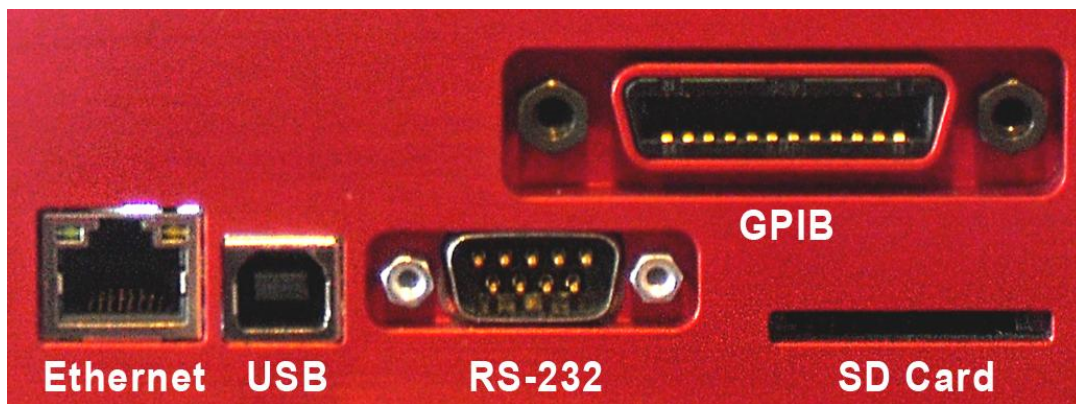
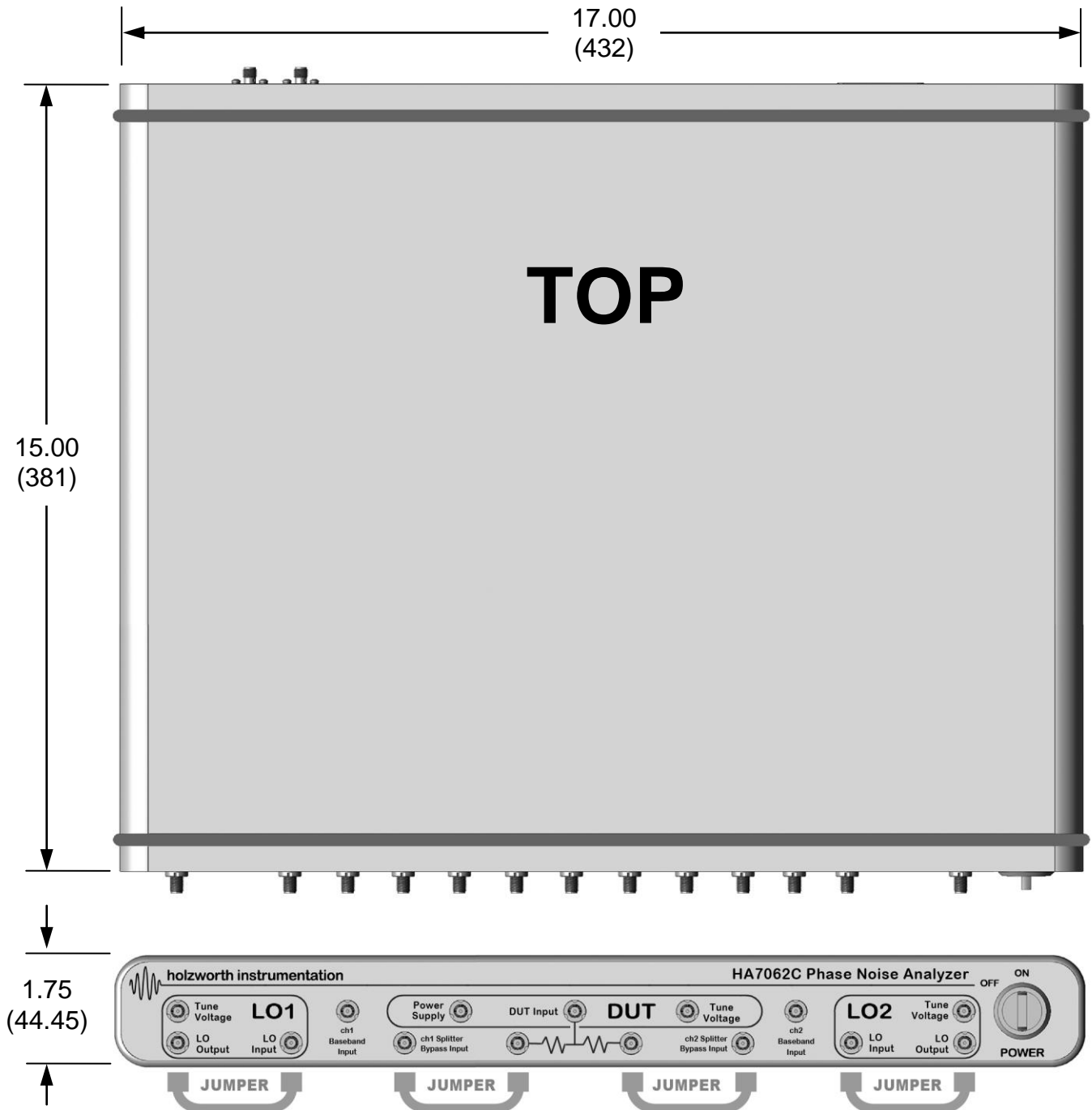

Figure 3: HA7402C Communication Ports

MECHANICAL DIMENSIONS

The HA7402C comes complete in a 1U high, rack mountable chassis. The chassis is a fan-less design to eliminate microphonics. A universal rack mount bracket kit is an available accessory (Part No.: RACK-1U). Mechanical dimensions are listed in inches (and millimeters).



STANDARD AC SUPPLY

The HA7402C utilizes an ultra-clean AC switching power supply. Units ship with a standard AC supply cable that is used to provide power to the instrument.



ENVIRONMENTAL

DESCRIPTION	SPECIFICATION (by design)
Operating Environment Temperature Humidity Altitude Vibration	+10C to +40C RH 20% to 80% at wet bulb temp. <29C (non-condensing) 0 to 2,000m (0 to 6,561 feet) 0.21 G-rms maximum, 5Hz to 500Hz
Storage (Non-Operating) Temperature Humidity Altitude Vibration	-10C to + 60C RH 20% to 80% at wet bulb temp. <40C (non-condensing) 0 to 4,572m (0 to 15,000 feet) 0.5 G-rms maximum, 5Hz to 500Hz

OPTIONS & ACCESSORIES

Holzworth offers options and accessories to optimize the analyzer for an intended application. Specify all required options and/or accessories when requesting a quotation or placing a purchase order.

PART No.	DESCRIPTION	CLASSIFICATION
OPT-DUT20	Enables DUT measurements to >20GHz via Internal LO Mode	OPTION
CASE-1U	Ruggedized Carrying Case with TSA security lock	ACCESSORY
RACK-1U	19" Rack mount bracket kit for HA7000 Series. "L" rear bracket.	ACCESSORY
RACK2-1U	19" Rack mount bracket kit for HA7000 Series. Straight rear bracket.	ACCESSORY

INCLUDED HARDWARE AND CERTIFICATIONS

Each product delivery includes specific, standard hardware and certifications.

TYPE	DESCRIPTION	COMMENTS
HARDWARE	HA7402C PHASE NOISE ANALYZER	DELIVERABLE
HARDWARE	AC POWER CABLE (Specify country at time of order)	DELIVERABLE
CERTIFICATE	ANSI z540.1 CALIBRATION CERTIFICATE	DELIVERABLE
WARRANTY	3 YEAR MANUFACTURER'S WARRANTY	NON-APPLICABLE
CERTIFICATE	CE COMPLIANCE CERTIFICATE <i>DIRECTIVE: 2004/108/EC, TEST STANDARD: EN 61326-1: 2006</i>	WEB DOWNLOAD
CERTIFICATE	RoHS COMPLIANCE CERTIFICATE <i>DIRECTIVE: 2002/95/EC</i>	WEB DOWNLOAD
CERTIFICATE	WEEE COMPLIANCE STATEMENT <i>DIRECTIVE: 2002/96/EC</i>	WEB DOWNLOAD

HA7402C OPERATION

The HA7402C performs all data processing internally. Measurement settings can be changed using serial commands sent to the HA7402C using any of the included communication options (see CONFIGURATION on page 9). Alternatively, measurement results can be read from the instrument directly without requiring a specific operating system. This capability provides unparalleled operational flexibility.

The hardware purchase includes a MATLAB™ compiled GUI for hardware operation and viewing/saving data. Each unit comes with an open license to operate the MATLAB™ Runtime based application on any standard PC. MATLAB™ Runtime is MathWorks shareware that can be used without the purchase of MATLAB™.

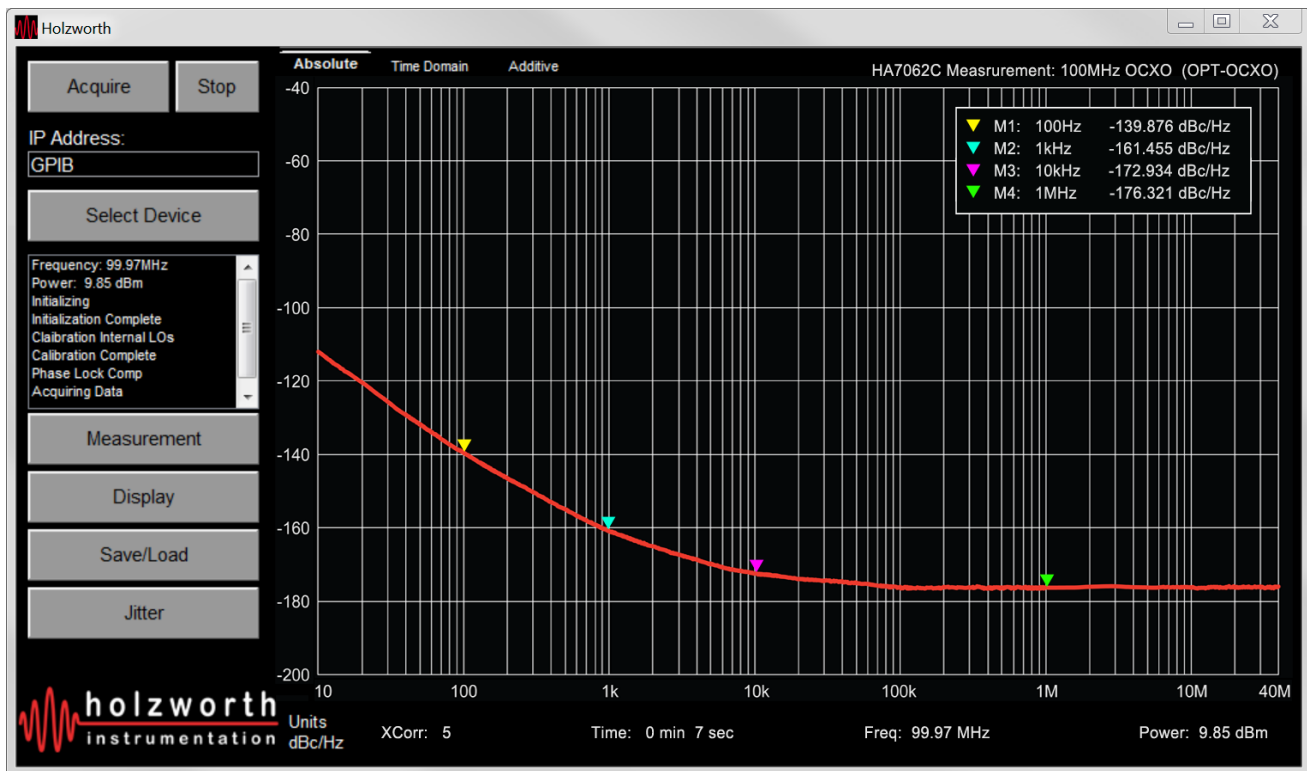

SOFTWARE

3 YEAR WARRANTY

All Holzworth phase noise analyzer products come with a standard 3 year 100% product warranty covering manufacturing defects. All product repairs and maintenance must be performed by Holzworth Instrumentation. Holzworth reserves the right to invalidate the warranty for any products that have been tampered with or used improperly. Refer to Holzworth Terms & Conditions of Sales for more details.

Holzworth products are proudly designed and manufactured in the USA.



CONTACT INFORMATION

Contact Holzworth directly for a product quotation, a product demonstration, or for technical inquiries.

Holzworth Instrumentation Sales Support

Phone: +1.303.325.3473 (option 1)

Email: sales@holzworth.com

Holzworth Instrumentation Technical Support

Phone: +1.303.325.3473 (option 2)

Email: support@holzworth.com

www.HOLZWORTH.com

